

Unbonded and Bonded Post-Tensioning Systems in Building Construction A Design and Performance Review

By Bijan O. Aalami¹

1 - INTRODUCTION AND SCOPE

The post-tensioning systems commonly used in building and bridge construction are grouped into two principal categories. These are the unbonded and the bonded systems.

The distinguishing characteristic of an unbonded tendon is that, by design, it does not form a bond along its length with the concrete. Unbonded tendons are generally made of single strand high strength steel, covered with a corrosion inhibiting coating and encased in a plastic sheathing (Figure 1). The force in the stressed tendon is transferred to the concrete primarily by the anchors provided at its ends. Variations in force along the tendon is effected by the friction between the strand and the tendon profile in the concrete member. Since the force in an unbonded tendon is transferred primarily by the anchors at its ends, the long-term integrity of anchors throughout the service life of an unbonded tendon become crucial.

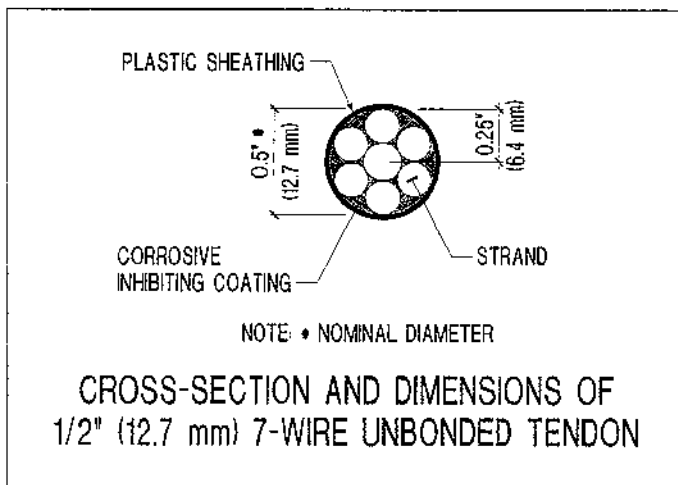

FIGURE 1

The function of the plastic sheathing is, (i) to act as a bond breaker; (ii) to provide protection against damage by mechanical handling, and (iii) to form a barrier against intrusion of moisture and chemicals. The strand coating, commonly referred to as grease, (i) reduces friction between the strand and the plastic sheathing, and (ii) provides added protection against corrosion.

Unbonded tendons are typically employed as monostrands, with each tendon having its dedicated end anchors. Also, tendons are stressed individually. Recently however, unbonded tendons consisting of groups of two, or more strands, each wrapped individually, but encased in a tough group sheathing have been introduced into the market in Europe and overseas.

Monostrand unbonded tendons have been in use in the United States since the late 1950s. Their application has been primarily in building construction. A short history of development of unbonded tendons is given in [Aalami 1990b]. In some literature, the unbonded tendons are referred to as debonded tendons.

The characteristic feature of a bonded tendon is that, by design, the tendon forms a continuous bond along its length with the concrete surrounding it. The bond is achieved through a cementitious matrix which surrounds the strands, commonly referred to as grout. It acts with the duct which is encased in the concrete member to complete the bond path between the prestressing strands and the concrete member. After stressing of a tendon, the grout is injected into the void of the tendon duct which houses the prestressing strands (Figure 2).

When the grout hardens, through its bond to the strand, it locks the movement of the strand within the duct to that of the concrete surrounding it. Hence, the force in a bonded strand becomes a function of the deformation of the concrete surrounding it. Figure 2 shows two examples from the many variations of bonded tendons. The flat duct tendon shown is for use in thin members, such as slabs. It houses up to either 4 or 5 strands placed side by side. The strands generally share a common anchor piece at each end, but are stressed and locked off individually. Corrugated, or smooth metal ducts, as well as corrugated plastic ducts are the materials of choice. Use of the flat plastic corrugated duct is more common in the US, whereas elsewhere, flat metal ducts are more widely used. The larger round ducts are for application in beams and deep members. The strands in these are stressed and locked off simultaneously using a specially designed multistrand stressing jack.

¹ Professor of Civil Engineering at San Francisco State University; Chair, Post-Tensioning Institute Technical Board; Principal, Bijan, Florian & Associates Inc, 1735 Woodside Rd, Redwood City; Ca 94061.

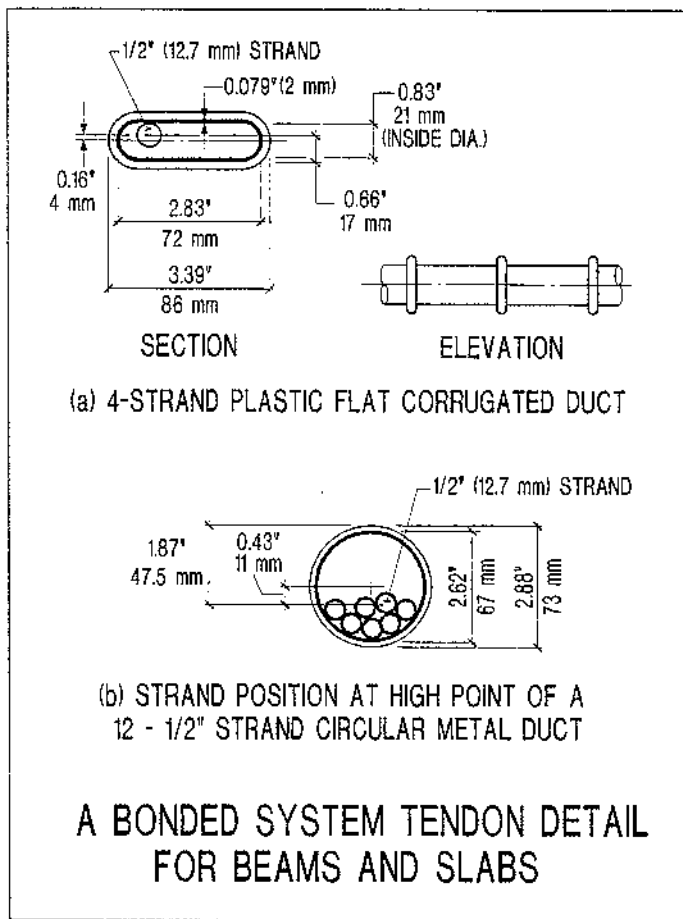

FIGURE 2

In this system, the function of the grout is: (i) to provide a continuous bond between the strand and the duct, (ii) to increase protection against corrosion by acting as a physical barrier to moisture penetration, and (iii) through its alkalinity, provide an environment non-conductive for corrosion. The function of the duct is: (i) to maintain a voided path for the strands in the concrete member during construction, (ii) to transfer the bond between the grout within the duct and the concrete surrounding, and (iii) to act as additional protection against penetration of moisture and chemicals into the interior of the duct. The principal function of the anchor assemblies at the ends is to hold the forces generated in the tendon at stressing, until the grout is introduced, hardened and cured. Bonded tendons are generally multi-strands. Tendons of up to 50 strands in one duct are not uncommon. Traditionally, the principal application of bonded tendons has been in bridge construction.

In recent years, there has been a growing tendency in the use of external tendons in new bridge construction, as well as in the retrofit of buildings. Many designers and investigators regard external tendons as a form of unbonded tendon construction. While admitting their likeness, this Technical Note does not address their application. The focus of this Technical Note is on tendons which are used in building construction, and which are contained within the body of the structural member they prestress.

In its infancy, and throughout later development, due to lack of knowledge, absence or inadequacy of relevant specifications and codes, and possibly shortsightedness or aggressive entrepreneur-

ship, unbonded post-tensioning systems, which today are viewed as systems with inherent flaws in their durability performance, were used. These problems are now well recognized and have been effectively addressed. Today, through a full understanding of the structural behavior, availability of strong analytical tools, matured specifications and codes [PTI 1993, ACI 1992, 1989], refined construction techniques [PTI 1994], improved materials and hardware, owners and engineers can fully realise the advantages of prestressing in their building projects. This Technical Note examines the features and performance of the unbonded and the bonded systems - as they are available today. It provides a comparative review of the merits of the two systems.

Let it be clear at the outset, both systems if designed, detailed and constructed according to current specifications and good practice, will provide durable structures meeting code intended serviceability and strength requirements. Or, if need be, both systems are capable to reach beyond the minimums stipulated in codes and produce a user-defined level of performance, in particular with respect to durability. The merits of each, and the selection of a system depends on the technology, the skilled labor and hardware readily available to the supplier, as well as the economics of construction in the local market area. None is blessed to be categorically superior to the other. The following review concludes with a numerical design example, giving the material quantities which are needed for a frame of a typical parking structure.

2 - ANALYSIS, DESIGN AND CONSTRUCTION

2.1 Analysis

Analysis is the computation of actions (moments, shears, and forces) and deformations in the prestressed structure under applied loading. Apart from losses in prestressing, which are somewhat different in nature and magnitude, the analysis procedure for the two systems is essentially the same.

The loss in prestressing force due to friction is higher in short and heavily profiled bonded tendons due to higher friction between the strand and its housing. For seating loss (wedge draw-in), and elastic shortening, the losses are the same for both systems. The long-term stress losses due to creep and shrinkage of concrete, and the relaxation in strand are different. For bonded tendons, these are subject to the local strain of concrete adjacent to the tendon, whereas for unbonded tendons these are taken to depend on the average precompression in the prestressed member.

Consider the three span beam of the structure in Fig. 3. For a comparison of tendon effectiveness, assume that both tendons have the same profile (Fig. 5, case c), and that all other conditions remain the same, as described in the design example in section 4. The in-service and strength limit state stresses for tendons of each system are calculated and summarized in Table 1 for comparison.

To simplify the comparison, the stresses are expressed as ratios of the average long-term stress in the unbonded tendon (last row of the table). This value for the parameters of the design example is 181.70

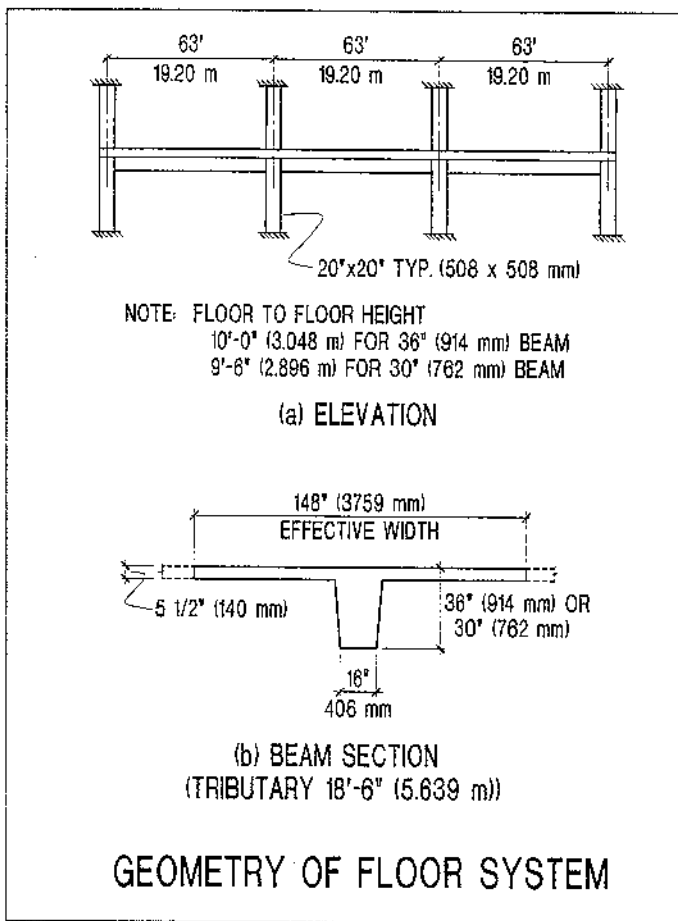

FIGURE 3

ksi (1.25 MPa). It is by coincidence that the in-service stresses over the second support (row 1 of the table) match the respective average stresses in the tendon. Due to the larger angular coefficient of friction, it is oftentimes believed that the immediate stress losses in bonded tendons are higher than a corresponding unbonded tendon. This perception is generally not valid for tendons with effective stressing lengths longer than approximately 80 ft or more (approx. 25 m). The high coefficient of wobble friction of the unbonded tendons soon wipes out the low friction advantage gained over bonded tendons for short stressing lengths.

It is also noteworthy, that since the long-term stress losses in bonded tendons at the second support is less than that of the unbonded case, the in-service stress is slightly higher. For the long-term loss computations the software used follows [Zia et al 1979]

TABLE 1: TENDON STRESS COMPARISONS

Stress ratio and Location	Post-Tensioning System	
	Unbonded	Bonded
Long-term in-service stress*	1.00	1.03
Stress at nominal strength*	1.15	1.38
Long-term in-service average stress	1.00	1.03

* At top of second support

The average force in the strand is a measure of a strand's effectiveness during the service life of the structure. This includes performance for lower cracking and deflection. The above comparison was made on the premise that the two strands can be placed with the same profile. In practice, however, due to the larger size of a bonded tendon, the effective drapes of a bonded tendon is generally less than that of its unbonded counterpart. Refer to Figs 5 and 6 for the maximum drapes attainable in the design example for the two systems. The impact of a lesser drape is reflected in the design example given in Figure 4.

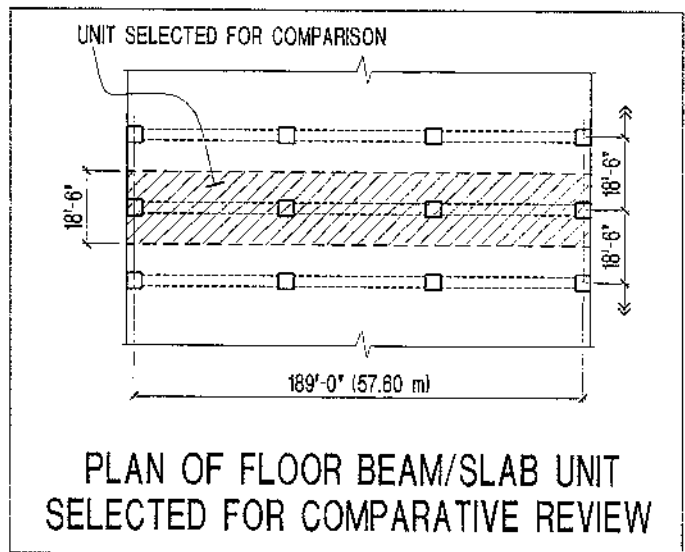

FIGURE 4

2.2 Design

At the design stage, using the governing building codes and construction practice, the magnitude of prestressing, the amount and disposition of nonprestressed steel, and the detailing of the prestressed member are finalized.

Using ACI-318 Building Code [ACI-1992], and the Uniform Building Code [UBC 1994] the principal items which affect the design and economy of a prestressed member are listed below. It should be noted that, building codes other than those used herein may impose different restrictions than those listed below. The application of most of the criteria quoted is self explanatory in the design example given.

Concrete Cover to Tendon for Fire Resistivity

Most building structures are designed for a 2-hour fire resistivity, some for a 3-hour rating. UBC Table 7-A gives the same value of cover for both bonded and unbonded tendons. ACI-318 does address this requirement.

Concrete Cover to Tendon for Protection Against Corrosion

ACI section 7.7 and UBC [UBC 1994] do not differentiate between unbonded and bonded tendons in this respect.

Permissible Service and Initial Stresses in Concrete

Same for both systems

Stresses in Tendon at Strength Limit State

These are different for the two systems. For the same initial stress and tendon profile, code formulas (ACI-318 section 18.7) yield a higher stress for bonded tendons. Table 1 gives a comparison of the two values applied to the example used herein.

Minimum and Maximum Level of Prestressing

Same for both systems

Minimum Nonprestressed Reinforcement

For crack control, there is no code prescribed minimum nonprestressed reinforcement for members prestressed with bonded tendons. Unbonded tendon construction, however, requires a code specified minimum amount of nonprestressed reinforcement installed for crack control (ACI - section 18.9). The amount and disposition of this minimum steel depends on whether the structure is designed as a one-way or a two-way system [Aalami 1994a]. For a one-way system, the minimum is a function of the geometry of the section. It does not depend on the level of prestressing. For the two-way system, however, the minimum at midspan is linked to the level of in-service stresses at that location. The midspan minimum can be eliminated if the tensile service stresses are confined to a certain low level as stated in the code.

Redistribution of Moments

It is permissible to redistribute the elastically computed moments, in order to utilize, partially, the post-elastic strength of a section. To take advantage of this limited redistribution, ACI requires (section 18.10.4.1) that, as a prerequisite, a minimum amount of nonprestressed steel be available at the section destined for redistribution. The ACI's requirement makes the application of this option to members designed with bonded tendons impractical, since under normal circumstances, the design does not conclude with the code required prerequisite amount of nonprestressed rebar. For this reason, in practice, redistribution becomes applicable to unbonded tendon systems only.

Punching Shear Capacity of Two-Way Slabs

There is no code difference in the treatment of the two systems

One-Way Shear Capacity of Beams and Slabs

There is no code difference in treatment of the two systems

Contribution in Resisting Wind Loads

There is no code difference between the two systems. Both systems are permitted to be utilized in full to resist actions imposed by wind forces.

Contribution in Resisting Seismic Loading

Both UBC and ACI are mute in the application of prestressing to resist seismic forces. When necessary other codes [BOCA 1993, SBC 1994] and specialists literature must be consulted. This item is reviewed in more detail in section on performance (Section 3 of this Technical Note).

UBC's Special Provision for One-Way Systems

For one-way systems prestressed with unbonded tendons, UBC requires that in addition to the regular design for prestressing, the member be designed to develop a nominal strength, by means other than prestressing, for a loading equal to its dead loading plus 25% of its unreduced live loading. In computing the nominal strength of the section, it is permissible to disregard the strength reduction factor used in regular design. This requirement is generally referred to as (D+0.25L) criterion.

This UBC's provision is a remnant of a cautionary misconception promulgated in the early days of post-tensioning on the potential of progressive collapse of continuous spans in a one-way system, should unbonded tendons of one span fail. UBC's stipulation is not followed by other codes.

Minimum Spacing of Tendons in Slabs

Individual tendons, or groups of tendons shall be spaced uniformly and not farther than 8 times the slab thickness (ACI-18.12.4), or 5 ft. (1.5 m) for normal construction and uniform loading. Closer spacing may be required for concentrated loading and unusual conditions.

This provision leads to a non-optimal application of the flat duct bonded system in common slab construction. Consider a 5.5 in. (140 mm) parking structure slab designed with 125 psi (0.86 MPa) average precompression, using 0.5 in (13 mm) strands, each providing 26 kips (116 kN) effective force. The required strand spacing would be:

$$\text{Spacing} = 26000 / (125 \times 5.5) = 37.8 \text{ in. (960 mm)}$$

Since the maximum permissible tendons spacing is: $8 \times 5.5 = 44$ in. (1.12 m), single unbonded monostrand tendons can be placed at 37 in. (960 mm) on center to satisfy this requirement. If a flat duct is used, based on this code provision, only one strand can be placed in each duct. Or, two strands can be used per duct, with ducts spaced at 44 in. (1.12 m) on center. In either case, it would mean an inefficient use of the duct, grout, and anchorage assemblies. Note that each anchor head is made for four to five strands, but will be used for one or two only.

For this reason, there have been several attempts in the past to develop a small diameter monostrand bonded system. In Canada several projects have been completed using this approach. Generally, however, this has not lead to widespread application. Although dual strand bonded tendon systems have been successfully used in Canada. A dual-strand-oval-duct bonded tendon system developed in Hawaii and tested on at least one large project, was abandoned due to placement and grouting difficulties,

2.3 Construction

Ease of construction depends to a great extent on the experience, the skill and the practice of the construction crew in the locale of the project. Comments on ease or difficulty of handling one or the other system are somewhat subjective. Nonetheless, the following conclusions appear to be commonly accepted.

Unbonded systems are easier and faster to handle and place. Once installed and secured, the unbonded tendon seems to retain its profile more faithfully compared to plastic flat ducts. Some plastic ducts are found to be too flexible about their weak axis. This requires them to be secured at closer intervals for profile control in the vertical plane (at 3 to 4 ft.; 1.0 to 1.3 m).

Due to the greater flexibility of unbonded tendons, compared to the strong axis stiffness of flat ducts, unbonded tendons can be more readily maneuvered in the horizontal plane to avoid interference with openings and inserts.

The practice of some construction crews is to place the empty flat duct first, and thread the strands into the duct after concreting is complete. This is particularly the case for round ducts holding more than four strands. The site threading is regarded by some contractors as an additional labor operation. Other contractors consider it as a time-saving feature, in that threading of tendons can take place on-site while the concrete is hardening. In addition, it eliminated shop fabrication of tendons.

Some plastic ducts are found to be sensitive to daily changes in temperature and need to be secured at more frequent intervals to maintain the placement tolerance in the vertical plane. A draw back of infilled duct scheme is the occasional problems with collapse of ducts, or blockage of ducts through intrusion of concrete in poor concrete construction.

There is also the obvious added labor of grouting the bonded tendons, subsequent to stressing. In addition to the cost of the grouting equipment and its maintenance, or its rent, the quality control in the grouting operation is a skill demanding task. Good grouting in many environments is essential to the long-term performance of a tendon.

For slab construction, the strands in the flat duct of a bonded system are generally all anchored into a single assembly, but are stressed and locked off individually. A single strand stressing jack is used. The single strand jacks are light and are normally handled by one person. For the beams, commonly a round duct containing usually 5 to 12 strands is used. The round duct strands are stressed simultaneously using a multistrand jack. The multi-strand jacks normally require more than a one-man crew, and require a hoist or other equipment for handling.

One perceived advantage of the bonded systems in construction time saving is that the strands are cut from strand packs at the site. Hence, factory fabrication is eliminated, thus reducing lead time. The same practice for unbonded tendon construction is used at least by one contractor in California. Site cutting and dead-ending of strands on site is practiced extensively in Panama for unbonded tendon construction.

3 - PERFORMANCE

3.1 Durability

Apart from the immediate economy, a major concern of owners is the maintenance and the durability of the post-tensioning system selected. Due to shortcomings inherent in some early post-tensioning sys-

tems, coupled with lack of specifications and poor workmanship, some buildings constructed with unbonded tendons have suffered from premature deterioration. While from a statistical point of view, the bulk of the unbonded post-tensioned buildings in North America have performed well, and are providing their design-intended service, the geographically localized few, which used poor quality materials, poor construction practice, and were lacking in design, have caught disproportionate attention.

For bonded tendons, there are too few examples in the building industry in north America to afford a credible comparison.

The extruded unbonded tendons of today, following PTI's specification [PTI 1993] are designed to provide the durability performance that is in line with other components of the building construction. Where the environment is aggressive, tendons specifically designed for aggressive environment must be used [PTI 1993]. In the corrosion protected unbonded systems, the entire length of the strand, and its projection beyond the anchor piece in the recess pocket, are covered with a corrosion inhibiting coating. The tendon sheathing is connected to all anchorages with a water tight seal. A plastic cap covers the tendon tail and the gripping parts of the anchorage. This ensures complete encapsulation from end to end of the tendon. The tendon assembly is tested to withstanding a hydrostatic pressure of 1.25 psi (0.0086 MPa) which is equivalent to a 3 ft. (approx. 1 m) head of water. Conscious of the corrosion potential and the benefits of long-term performance, some engineering consultants insist on the use of encapsulated tendons for certain classes of construction, such as mat foundations, packing structures and slab-on-ground, regardless of the geographical location.

It is interesting to note that with the improvement in the quality of unbonded tendons, designed for aggressive environments, a growing number of engineers and owners are preferring the unbonded tendons to the bonded alternative. As an example, in Taiwan, where bonded tendons are the norm, the recently constructed prestressed digesters (Pali digesters) were specifically built using unbonded tendons, on the premise that the new unbonded tendon technology can better resist the humid climatic conditions [Sutter et al 1994]. The same is true for Singapore in the construction of the Kronji digesters [Aalami 1994]. The unbonded tendon systems selected are designed to provide superior protection for use in an aggressive environment. Also, a new incrementally launched bridge currently being constructed in Austria is using corrosion resistive unbonded tendons [Eibl, 1994]. In Germany too, a traditionally bonded tendon territory, unbonded prestressing is being increasingly introduced in building construction. A prominent example is the recent construction of the Landescreditbank building in Stuttgart.

The principal shortcoming in durability problem of bonded tendons lies in poor grouting, low quality grout, and corrosion of ferrous ducts. When constructed correctly, bonded tendons exhibit excellent durability [ASBI 1994]

3.2 Replaceability, Repair

A damaged or deteriorated strand from an unbonded tendon can be readily pulled out of its sheathing and replaced by a new one. This provides great flexibility in repair and retrofit of existing buildings post-tensioned with unbonded tendons. Oftentimes, a smaller diameter, but higher strength strand is used for replacement. Since the long-term stress losses in replaced tendons are much less than those placed in new construction with green concrete, in most cases, the replaced strand can be equally or more effective than the one replaced. Also, cut, or ruptured tendons can be recovered and restored using splicing and/or a number of other techniques.

On the other hand, because of the continuous bond along their length, the bonded tendons do not offer the replacement flexibility available for unbonded tendons.

3.3 Serviceability index

The serviceability index of a tendon is a measure of that tendon's contribution to the overall serviceability and strength of the structure of which it is a part. It is used to express the impact, on the overall performance of the structure, of a localized failure of a tendon.

The function of an unbonded tendon rests on its integrity along its entire length and the end anchorages. Loss of force at any one point along the tendon, leads to loss of force along the entire length of that tendon. Hence, a tendon is either effective along its entire length, or not effective at all. The frictional forces present in the unbonded tendons do not change this scenario to a significant extent. The longer a tendon, the larger is its contribution to the overall serviceability and strength of the structure. Hence, in general, local failure in a long tendon leads to larger potential damage to the structure, in contrast to a local failure in a short tendon. A long unbonded tendon is calculated to have a larger serviceability index. Therefore, continuous protection of an unbonded tendon along its entire length becomes a critical issue. Anchorage integrity too, is of utmost importance throughout the useful life of a tendon.

A bonded tendon on the other hand, is capable to develop its force at a distance along its length approximately equal to 50 times the strand diameter. Should an anchor fail, or should there be a local failure in the strand, such as a strand being severed, the loss of force would be local. The remainder of the tendon, if in fact, would retain its force at the development length away from the failure point and would remain functional. For this reason, the serviceability index of a bonded tendon is not directly related to the tendon length. It is a function of the tendon's development length.

Tendon serviceability index is discussed elsewhere [ADAPT 1992]. It suffices to record herein that bonded tendons, having a lower index, exhibit a lesser detrimental impact on the structure, should they fail locally.

3.4 Response to Seismic forces

ACI and UBC building codes [ACI 1992, UBC 1994] are mute about the use of prestressed tendons in resisting seismic forces in building

construction. However, both BOCA and SBC [BOCA 1993, SBC 1994] specifically recognize the contribution of prestressed tendons to resist seismic forces. Some designers are concerned about the use of unbonded tendons to resist seismic forces because they feel these have reduced hysteretic energy absorption compared to monolithic reinforced concrete of similar strength and elastic stiffness. The reduced energy dissipation is equated, without theoretical justification to poor seismic performance. In fact, performance may be better than bonded post-tensioned beams, where loss of prestress is likely to result in inelastic strains develop in the prestressing tendon: [Priestley, et al 1994, Priestly, et al 1993]. Priestly [1994] shows that by use of unbonded tendons, it should be possible to develop a joint which retains its initial stiffness after inelastic response to seismic forces. When unbonded tendon are used, only a modest increase in displacements can be expected, compared to nonprestressed frames of similar strength. Since, due to a greater stiffness compared to steel frames, the seismic drift in concrete structures is generally not as critical, the modest increase in displacement associated with unbonded tendon construction does not appear to pose a concern.

BOCA and SBC articulate an acceptable level for contribution of post-tensioned tendons in resisting seismic forces [BOCA 1993, SBC 1994]. Post-tensioning tendons are permitted in flexural members of frames designated to resist seismic forces, provided the average pre-compression in the member's section, as calculated according to the code provisions does not exceed 350 psi (2.41 MPa). However, the prestressing must be used in conjunction with nonprestressed reinforcement to resist the forces. The prestressing tendons shall not provide more than one quarter of the strength for both positive and negative moments at the joint face. BOCA's and SBC's recommendation do not differentiate between unbonded and bonded tendons.

The preceding discussion focuses on the contribution of post-tensioning in members designated as part of the primary seismic resisting system of a structure. Evidently, post-tensioning is widely in use in members secondary to the primary seismic system, such as slabs acting as diaphragms, or gravity designed post-tensioned beams acting as drag or chord members. Observations, in past earthquakes, of the response of the members post-tensioned with unbonded tendons have revealed excellent performance [Aalami, et al 1990a]

3.5 Flexibility in Remodeling

There is a misconception among some engineers and owners, that floor systems constructed with unbonded tendons do not provide adequate flexibility for remodeling, when it becomes necessary to cut large openings in a slab. This is not strictly true. Theoretically, openings that can be made in a floor slab reinforced with one post-tensioning system, can also be made with the other. The difference lies in the ease of execution. Bonded tendons can be handled with greater ease.

In the case of an unbonded system, the location of the tendons within the cut region must first be established. Tendons are then cut, de-stressed, and re-anchored at the face of the opening using specialized techniques [PTI 1990]. In the bonded system, however, tendons are cut, but need not be re-stressed and anchored, since the grout in the uncut region would generally hold the tendon in position. The remodeling operation for the unbonded system is more involved, but certainly practical and common.

3.6 Demolition

Floor systems reinforced with either bonded, or unbonded post-tensioning can be readily demolished, each requiring diligence specific to the system used and the particulars of the structure [Barth et al. 1989, Chacos 1991]. Unbonded tendons of the non-extruded type [Aalami 1990b] tend to eject from the face of the slab when cut. The ejection, if any, is far less for the extruded tendons (generally less than 18 in.; 450 mm). In either case, a greater degree of care and safety precaution must be exercised when dismantling a structure reinforced with unbonded tendons. Also, apart from the potential of tendon/wedge ejection, the question of progressive collapse must be investigated.

4 - CASE STUDY

4.1 Definition of problem

A parking structure with beam and one-way slab construction is considered. The overall geometry of the structure is shown in Figs. 3 and 4. The parallel beams, 18.5 ft. apart (5.64m) span three bays, each 63 ft. (19.2m) long. Other particulars of the geometry are reflected in the figures.

Two design options are reviewed. In the first option, the members are sized according to the ACI code. The second option uses UBC. For economy in design and construction, the beams sized according to UBC are generally deeper (36 in.; 914 mm), than those sized according to ACI (30 in.; 762 mm). The difference is triggered by the $(D+0.25\%L)$ criterion of the UBC, when using unbonded one-way construction. The floor to floor level for the ACI design is 9.5 ft. (2.90 m), that for UBC is 10 ft. (3.05 m). The same thickness of slab (5.5 in.; 140 mm) is used in both cases. The slab thickness selected is on the high side. A 5 in. (127mm) slab would be a more common selection for California construction.

4.2 Design Summary

The material quantities of the two designs performed are given next:

Figure 5 is a listing of the beam designs for both beam-depth options. The post-tensioning and nonprestressed steel (rebar) entered below each design includes the beam reinforcement for both flexure and shear. Note that for the 36 in. option, the bonded system design required more post-tensioning, but less rebar. The requirement for additional post-tensioning is due to the size of the duct and subsequently the smaller drape available for the bonded system. It is also noteworthy that for the 36 inch option there is practically no difference, in material quantities, between the design of the unbonded systems according to the ACI and the UBC. This is probably the reason behind the use of a 36 in. deep beam, as a standard for beam and slab parking structures, where UBC is enforced. The selection effectively utilizes the rebar of $(D+0.25\%L)$ requirement in strength design of the prestressed condition. For the 30 in. (762 mm) deep beam, the prestressing is the same for all options. The increase in rebar for the unbonded option is due to the minimum requirements.

The slab design is shown in Fig. 6. Observe that for the slab thickness

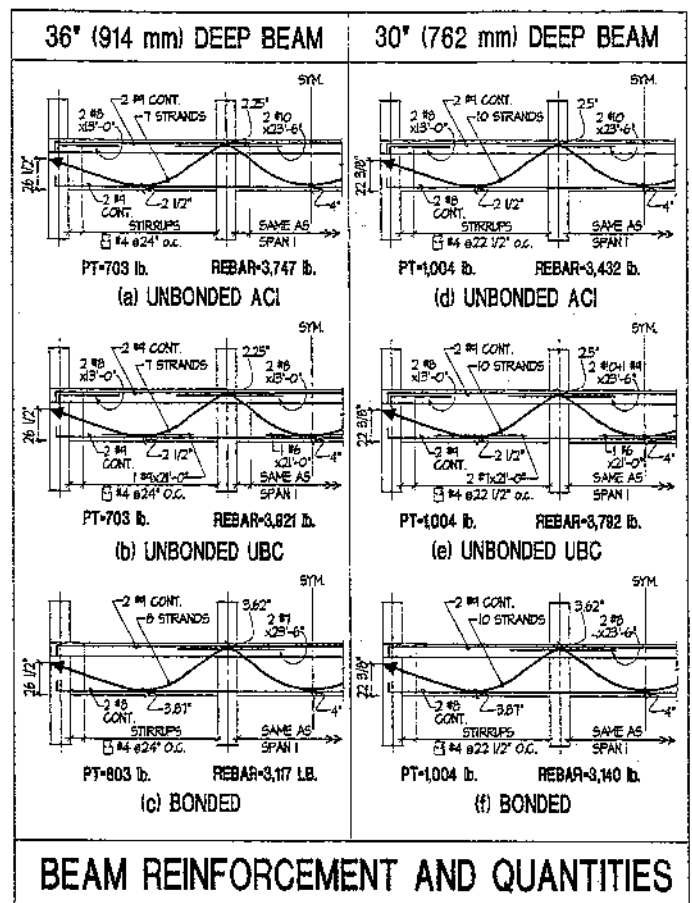

FIGURE 5

selected, the ACI and the UBC result in the same design for the unbonded system. Both the bonded and the unbonded system have the same amount of prestressing, but rebar for the unbonded system

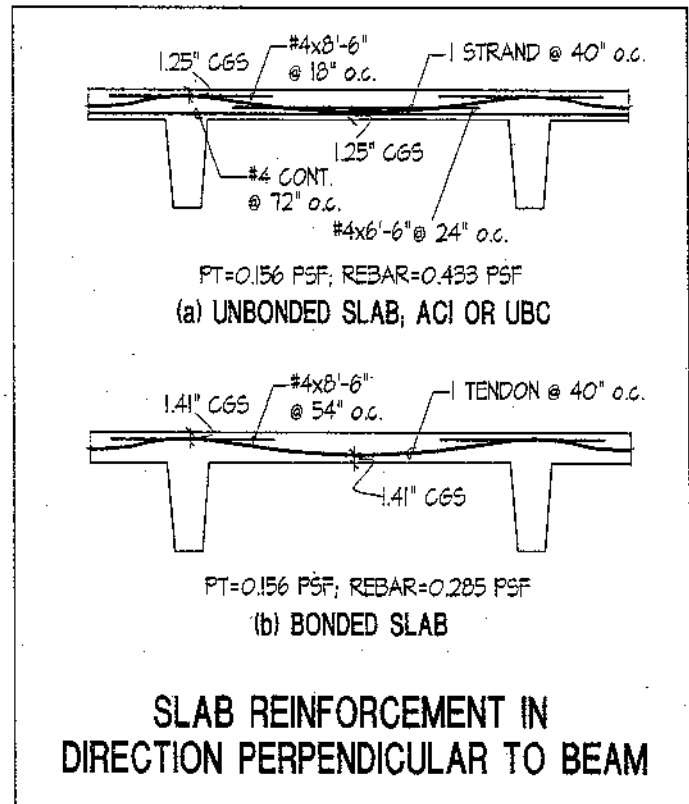

FIGURE 6

is more.

Figure 7 illustrates the code required shrinkage rebar together with the support bars. The reinforcement is the same for all the 6 design options reviewed.

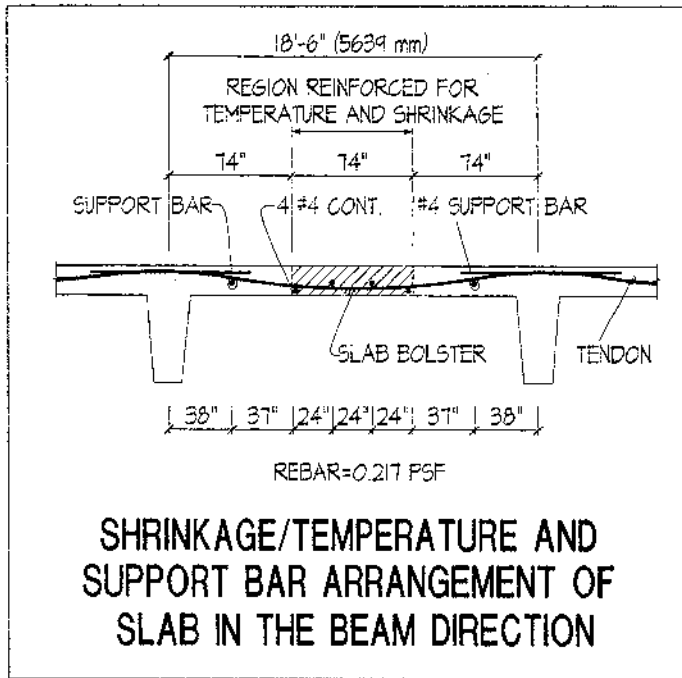

FIGURE 7

Table 2 lists the summary of the quantities needed. Table 3 is a comparative description of total reinforcement used for the six options. It considers the reinforcement for the 36 in. (914 mm) ACI design as base reference (last two columns), and compares the requirements of the other options as a ratio to the standard case. In addition, to enable quantity estimates, the average per unit area of reinforcement needed is given below the table.

TABLE 2: SUMMARY OF TOTAL REINFORCEMENT REQUIREMENT FOR THE REFERENCE FLOOR UNIT (18.5 ft. x 189 ft.; 5.64m x 57.6m)

Beam Depth			Beam		Slab Bay		Total	
			Rebar	PT	Rebar	PT	Rebar	PT
36 in. (914mm)	Unbonded	ACI	3.747	703	2.273	545	6.020	1.248
		UBC	3.921	703	2.273	545	6.194	1.248
	Grouted	-	3.117	803	996	545	4.113	1.348
30 in. (762mm)	Unbonded	ACI	3.432	1.004	2.273	545	5.705	1.549
		UBC	3.792	1.004	2.273	545	6.065	1.549
	Grouted	-	3.140	1.004	996	545	4.136	1.549

Note: Values are in lbs, multiply by 0.453 to convert to kg.
PT = Post-tensioning

TABLE 3: COMPARATIVE SUMMARY OF TOTAL REINFORCEMENT REQUIREMENTS FOR A COMPLETE TRIBUTARY*

Beam Depth			Reinforcement Ratios**	
			Rebar	PT
36 in. (914mm)	Unbonded	ACI ***	1	1
		UBC	1.029	1
	Bonded	-	0.683	1.080
30 in. (762mm)	Unbonded	ACI	0.948	1.241
		UBC	1.007	1.241
	Bonded	-	0.687	1.241

* See figure defining floor coverage and components

** Ratios of required reinforcement to reference case

*** Reference case: Rebar = 1.722 psf (8.43 kg/m²)

PT = 0.357 psf (1.75 kg/m²)

4.3 Details of Design Parameters and Criteria

The following design parameters and criteria were used to arrive at the values reported in the comparative analysis.

4.3.1 Geometry

The structure is a multi-level beam and one-way slab construction. The spans and dimensions are given in Fig. 3. Columns are 20 in. (508 mm) square and extend above and below the floor slab. One floor level with columns above and below is considered. In the analysis, the far end of columns is assumed fixed against rotation

4.3.2 Loading

Slab

Selfweight (5.5/12) × 0.15 = 0.069 ksf (3.304 kN/m²)

Electrical, mechanical and misc 0.005 ksf (0.239 kN/m²)

Total 0.074 ksf (3.543 kN/m²)

Live loading: either 0.050 ksf (2.39 kN/m²)
or 2 kips (8.89 kN) concentrated loading

Beam

Selfweight

Slab: 0.074 × 18.5 = 1.369 k/ft (19.98 kN/m)

Beam stem

30 in. (762 mm) deep beam:
(24.5 × 16) × 0.15/144 = 0.408 k/ft (5.96 kN/m)

36 in. (914 mm) deep beam:
(30.5 × 16) × 0.15/144 = 0.508 k/ft (7.42 kN/m)

Total selfweight:

30 in. (762 mm) beam :
1.369 + 0.408 = 1.777 k/ft (25.93 kN/m)

36 in. (914 mm) beam :
1.369 + 0.508 = 1.877 k/ft (27.39 kN/m)

Live loading:

The governing live loading is the uniformly distributed load of 50 psf (2.39 kN/m²)

Reduction in live load $R=0.08 \times (63 \times 18.5 - 150) = 81\% > 40\%$
40% governs

$LL = (1-0.4) \times 18.5 \times 0.05 = 0.555 \text{ k/ft (8.10 kN/m)}$

4.3.3. Material

Concrete:

$f'_c = 4000 \text{ psi (27.6 MPa)}$

Aggregate 3/4 in. (19 mm), hard rock

Prestressing:

0.5 in. (12.7 mm) diameter, 270 ksi (1860 MPa)-

ASTM A-416, seven wire, low relaxation strand

Nonprestressed reinforcement:

Grade 60, $f_y=60 \text{ ksi (413 MPa)}$ for both flexure and stirrups

Bar size: #5 (16 mm) for slab; max #9 (28mm) for top bars in beam; max #8 (25 mm) for bottom bars in beam; #4 (13 mm) bars for beam stirrups

4.3.4 Criteria

Codes: ACI[1992, 1989], and UBC [1994]

Service stresses

Maximum tension: $9\sqrt{f'_c}$ (0.75 $\sqrt{f'_c}$; MPa)

Maximum compression: $0.4 f'_c$

Average precompression

Slab: 125 psi (0.86 MPa)

Beam: 150 psi (1.03 MPa)

The average precompression selected for the design is at the lower end of the permissible range. This was chosen, because it will afford a more explicit differentiation between the designs of the two post-tensioning systems. Selection of prestressing more than the minimum required to meet the tensile fiber stress requirements, or the strength demand, tend to eliminate the differences in material quantities between the two systems.

Adjustment in moments

Redistribution of moments used for unbonded systems

Beam and slab *stiffness increased* over the supports [ADAPT 1993]

Moments *reduced to face-of-support*

Live load pattern

Live load skipped with a skip factor of 1

Cover to prestressing tendon and nonprestressed reinforcement

Cover is determined based on fire rating and protection against corrosion.

(i) Fire rating: 2 hours, Table 7-A (item 4)

First support and midspan considered unrestrained, second

support and interior spans considered restrained.

For prestressing:

Slab: End span 1.5 in. (38 mm)
Interior spans 0.75 in. (19 mm)

Beams: Wider than 12 in. (305 mm),
End span 2 in. (51 mm)
Interior span 1.5 in. (38 mm)

For nonprestressed reinforcement (UBC, Table 7-A, items 5 and 7)

Slab: 1 in. (25 mm)
Beams: 1.5 in. (38 mm)

(ii) Concrete cover protection against corrosion:

ACI-318-92 (section 7.7) applies both to prestressed and non-pre-stressed reinforcement. For prestressing it applies to duct. For concrete exposed to weather.

Slab 1 in. (25 mm)
Beam 1.5 in. (38 mm) (to stirrup)

Effective width

Use beam stem plus 12 times slab thickness on each side

Effective width = $16 + 24 \times 5.5 = 148 \text{ in. (3759 mm)}$

Prestressing loss data

Seating loss (wedge draw-in): 0.25 in. (6 mm)

Stressing: Both ends

Jacking stress: 0.80 ultimate

Stressing day: 3rd day

Concrete strength at stressing: 3000 psi (20.7 MPa)

Concrete modulus of elasticity: $E_{ci} = 3,122 \text{ ksi (21,500 MPa)}$

Friction coefficients:

For unbonded tendon

Coefficient of angular friction: $\mu = 0.070 / \text{rad.}$

Coefficient of wobble friction: $K = 0.0014 / \text{ft.}$
(0.0046 /m)

For bonded tendons

For slab: using flat plastic ducts

Coefficient of angular friction $\mu = 0.14 / \text{rad.}$

Coefficient of wobble friction $K = 0.0002 / \text{ft.}$
(0.000656 /m)

For beams: using round metal corrugated duct

Coefficient of angular friction: $\mu = 0.20 / \text{rad.}$

Coefficient of wobble friction: $K = 0.0002 / \text{ft.}$
(0.000656 /m)

Volume to surface ratio:

For slab = 2.75 in. (70 mm)

For beams

for 36 in. (914 mm) = 3.65 in. (93 mm)

for 30 in. (762 mm) = 3.50 in. (89 mm)

Relative Humidity: 80 %
Stressing at: 3rd day

Superimposed DL/total DL:

For the bonded construction

for 30 in. (762 mm) deep beam = 0.052

for 36 in. (914 mm) deep beam = 0.050

Shrinkage reinforcement

Used 0.0018 times area outside effective width (ACI-318)

4.3.5 Analytical and Design Tool

For the comparative study ADAPT post-tensioning software system [ADAPT-TS, 1993] was used. ADAPT-TS is a commercially available software for analysis and design of bonded and unbonded floor systems. The variable force option of the software was used. In this option, the actual number of strands selected are used in the analysis. Loss of immediate and long-term stress along the tendon is integrated into the analysis.

4.4 Two Way Systems

In two-way slab construction, the unbonded system compares more favorably to a bonded system similarly designed because: (i) the UBC criterion of $(D+0.25\%L)$ does not apply to two-way systems, and (ii) due to generally shallow depth of slabs, the loss of drape due to duct size becomes more significant. This places the bonded construction at a disadvantage.

5 - REFERENCES

- Aalami, B. O., (1994a), "One-Way and Two-Way Post-Tensioned Floor Systems," PTI-TN 3, Post-Tensioning Institute, Technical Notes 3, Phoenix, Az, 10pp (1994).
- Aalami, B. O., (1994b) "Kranji Sewage Treatment Egg-Shaped Digesters, Preliminary Design," Bijan, Florian & Assoc. Inc, Redwood City, Ca, 1994.
- Aalami, B. O., Barth, F. G., Napior, K., and Pu, D., (1990a), "Earthquake Performance of Unbonded Post-Tensioned Buildings," Post-Tensioning Institute, Phoenix, Az, 16 pp., 1990.
- Aalami, B. O. (1990b) "Developments in Post-Tensioned Floors in Buildings," FIP XI Congress Proceedings, S3-S9, Hamburg, 1990.
- ACI-318 (1992), "Building Code Requirements for Reinforced Concrete," American Concrete Institute, Detroit, MI, pp. 347, 1992.

ACI-423 (1989), "Recommendations for Concrete Members Prestressed with Unbonded Tendons," American Concrete Institute, Detroit, MI, pp. 18, 1989.

ADAPT TS, 1992, Post-Tensioning Analysis and Design Software, ADAPT, 1733 Woodside Rd, Suite 260, Redwood City, Ca 94028, 1992.

ASBI, (1994), "American Segmental Bridge Institute Newsletter," Vol. 22, Summer 1994, also Vol 19, Fall 1993.

Barth, F. G., and Aalami, B. O. (1989), "Controlled Demolition of an Unbonded Post-Tensioned Concrete Slab," Post-Tensioning Institute, Phoenix, Az, 32pp, 1989.

BOCA, (1993), "National Building Code," Building Officials and Code Administrators International Inc., Country Club Hills, IL, pp 342, 1993.

Chacos, G., P., (1991) "Demolishing of a Post-Tensioned Parking Garage," Concrete International, American Concrete Institute, Oct., pp. 44-46, 1991.

Eibl, J., Koblner, G., and Huang, J., (1994) "Unbonded Prestressing of Bridges in Germany," Spannbeton in der Bundesrepublik Deutschland 1990-1994," Deutscher Beton-Verein E.V. pp. 84-89, 1994.

Priestly, M. J. N., and MacRae, G. A., (1994), "Precast Seismic Resisting Frames Using Unbonded Prestressing Tendons," FIP'94 XII Congress Proceedings, pp. E10-E15, 1994.

Priestly, M. J. N., and Tao, J., (1993) "Seismic Response of Precast Concrete Frames With Partially Debonded Tendons," PCI Journal, Jan-Feb 1993.

PTI (1994), "Field Procedures Manual for Unbonded Single Strand Tendons," 2nd edition, Post-Tensioning Institute, Phoenix, Az, pp. 62, 1994.

PTI (1993), "Specifications for Unbonded Single Strand Tendons," Post-Tensioning Institute, Phoenix, Az, pp.16, 1993.

PTI (1990), "Post-Tensioning Manual," Post-Tensioning Institute, fifth edition, Phoenix, Az, pp. 406, 1990.

SBC, (1994), "Standard Building Code," Southern Building Code Congress International Inc, Birmingham, Al, pp 762, 1994.

Sutter, Gerhard, and Jaeger, Peter, (1994) "Egg-Shaped Anaerobic Digesters, Taiwan," Structural Engineering, International, IABSE, Vol 4, No. 3, Aug. 1994, pp. 160-163.

UBC, (1994), "Uniform Building Code," International Conference of Building Officials, Whittier, Ca, Vol. 2, pp. 1339, 1994.

Zia, P. H., Peterson, K., Scott, N. L., and Workman, E. B. (1979), "Estimating Prestress Losses," Concrete International, American Concrete Institute, pp. 32-36, June 1979.

6 - ACKNOWLEDGMENT

In the preparation of the material presented in this Technical Notes, the inputs received from VSL Corporation (Western Region), and Ing. Roberto Roy, of Estructuras Postensadas S.A., are greatly appreciated. This work has also benefitted from good suggestions and comments made by Mr Gerry McGuire, Executive Director of the Post-Tensioning Institute.

Please contact the Institute, or the editor, Dr. Bijan Aalami, for contributions, comments and suggestions for the future issues.



POST-TENSIONING INSTITUTE

Technical Notes

ISSUE 5 • SEPTEMBER 1994

1717 WEST NORTHERN AVENUE, SUITE 114, PHOENIX, ARIZONA
(602) 870-7540 FAX (602) 870-7541

This publication is intended for the use of professionals competent to evaluate the significance and limitations of its contents and who will accept responsibility for the application of the materials it contains. The Post-Tensioning Institute reports the foregoing material as a matter of information and therefore disclaims any and all responsibility for application of the stated principles or for the accuracy of the sources other than material developed by the Institute. The Post-Tensioning Institute in publishing these Technical Notes makes no warranty regarding the recommendations contained herein, including warranties of quality, workmanship or safety, express or implied, further including, but not limited to, implied warranties of merchantability and fitness for a particular purpose. THE POST-TENSIONING INSTITUTE SHALL NOT BE LIABLE FOR ANY DAMAGES, INCLUDING CONSEQUENTIAL DAMAGES, BEYOND REFUND OF THE PURCHASE PRICE OF THIS ISSUE OF TECHNICAL NOTES. The incorporation by reference or quotation of material in the Technical Notes in any specifications, contract documents, purchase orders, drawings or job details shall be done at the risk of those making such reference or quotation and shall not subject the Post-Tensioning Institute to any liability, direct or indirect, and those making such reference or quotation shall waive any claims against the Post-Tensioning Institute.



Printed on recycled paper.

PRINTED IN U.S.A.

Sims 3.5M © PTI 9/94